

The **CENTROID A532 5-axis Cylinder Head Machining Center**, equipped with a 10HP spindle, 24-tool ATC, and a heavy-duty box-way design, is far more than *just* a porting machine. Easily adaptable to any automotive machining need, everything from motorcycle heads to big blocks, aluminum to cast iron, steels, and exotics can be machined with the A532. Our tilting-rotary table provides +/- 32° of tilt (64° total) to reach into the toughest ports while our patented ballscrew design with heavy-duty axle provides unmatched accuracy and rigidity over traditional designs. Included with each machine are all the turnkey extras you'll need to start producing race-winning cylinder heads, and our proven personalized training program will have you in production faster than any other system on the market. Contact your representative today to schedule a demonstration and discover for yourself why the CENTROID A532 is the world's leading cylinder head machining center.



**CENTROID™**

**A532**  
5-Axis Cylinder Head Porting

**A532 Machine Specifications:**

Table Size:	18" x 56" (457 x 1422mm)
Longitudinal travel (X):	41" (1041mm)
Cross travel (Y):	21" (533mm)
Vertical travel (Z):	34" (863mm)
Spindle nose to table top:	39" (990 mm)
Spindle center to column:	22" (659mm)
Maximum table load:	2420lbs (1100kg)
Spindle power:	10HP/7.5kW
Spindle taper:	CAT40 / BT40
Spindle speed:	6000 RPM
Rapid feed rates (X,Y,Z):	X-400, Y-400, Z-350 IPM
Accuracy:	0.0005" (0.0127mm)
Repeatability:	0.0002" (0.0060mm)
Axis drive motors (X,Y,Z):	1kW AC Brushless Servos
Coolant pump:	1/8HP 55 Gallon Capacity
Auto lubrication pump:	150W 1.75 Liter Capacity
Power requirement:	14kVA, 50-60Hz, 208-240v, 3 Phase
Air requirement:	90-100 PSI (6.2-6.8 Bar)

**Tilt Table Specifications:**

Distance between centers:	25" (635mm)
Maximum tilt (B):	+/- 32° (64°)
Rotation (A):	360°
Minimum indexing unit:	0.0005°
Axis drive motors (A,B):	750W AC Brushless

**Included Software:**

In addition to **Mastercam** Multi-Axis with Verify and 1st year Mastercam Maintenance, the CENTROID control includes: Intercon conversational software, digitizing and probing cycles, graphical program preview, automatic tool measurement, cutter radius compensation, unlimited file size, sub programs and macros, part scaling and mirroring, rigid tapping, compression tapping, multiple work coordinate systems, coordinate system rotation, programmable spindle speed, and extensive canned cycles including boring, pocketing, and threadmilling.

**Warranty:**

One year standard warranty for parts, labor, and technical support

**More Than Just a Porting Machine**



**Additional Machining Capabilities**

- Billet cylinder heads
- Manifold port matching
- Throttle bodies
- Turbo/exhaust flanges
- Screw-in rocker stud conversions
- Fuel pump adapters
- Spring pockets
- Seat and guide bores
- Billet intake runners
- Clutch floaters
- Engrave letters, numbers & logos

**Optional Features**

- 15 or 20HP dual vector drive spindle
- 8000 RPM spindle with chiller
- Through-spindle coolant (TSC)
- Chip augers

**Machine Footprint**

Length:	134" (3404mm)
Width:	92" (2337mm)
Max Height:	123" (3124 mm)

**Shipping Footprint**

Length:	95" (2413mm)
Width:	100" (2540mm)
Height:	117" (2972mm)

**Weight**

Machine:	10,077lbs (4,570 Kg)
Tilt Table:	555lbs (253 Kg)

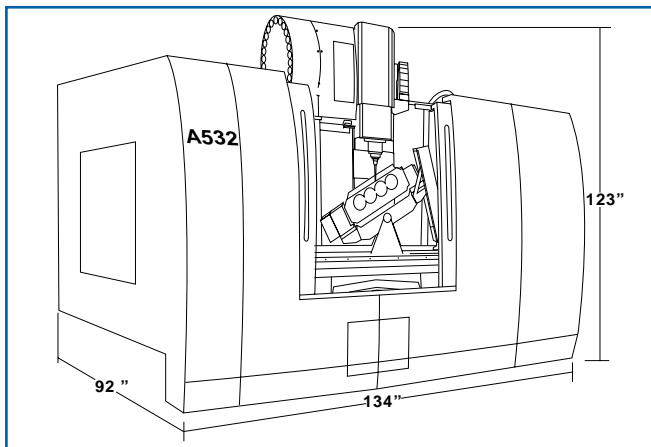

**CENTROID**  
159 Gates Rd.  
Howard, PA 16841  
(814) 353-9256 ext. 101 Sales  
(814) 353-9265 Fax  
© [www.centroidcnc.com](http://www.centroidcnc.com)

**Do More With a CENTROID!**



Copyright © 2009 CENTROID rev 14 2009-11-25  
Specifications subject to change without notice.  
Mastercam® is a registered trademark of CNC Software, Inc.

### ① Digitize

From combustion chambers to intake and exhaust ports, the CENTROID automatically digitizes your heads in 5-axis right on the machine. No expensive standalone required and nothing extra to purchase.

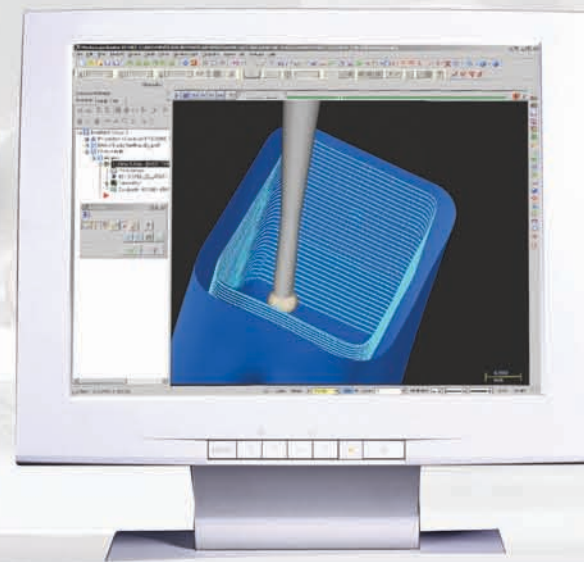

### ② Create

The digitized data is exported to Mastercam where an exact copy of the port can be made, or the data analyzed and modified to create the ultimate design. Toolpaths and the resulting CNC programs are generated.

### ③ CNC Port

The CNC programs are imported into the CENTROID control via USB or Ethernet. Exact copies of the design are produced every time and the entire cylinder head can be machined unattended thanks to the included automatic tool changer.

### Turnkey System Includes

- ✓ 5-axis machining center
- ✓ M400 5-axis CNC control
- ✓ Patented +/- 32° tilting rotary table
- ✓ **Mastercam** CAD/CAM software
- ✓ 10 days of personalized CNC porting training
- ✓ Digitizing probe & software
- ✓ Carbide lollipop porting tool
- ✓ Auto tool length setter
- ✓ Cylinder head fixture plate
- ✓ 24-tool automatic tool changer (ATC)
- ✓ Two CAT 40 tool holders
- ✓ MPG electronic handwheel
- ✓ Industry's best warranty & support

### Personalized Training



Our skilled technicians will teach you how to reproduce your race winning designs with ease. The personalized training course is tailored to your specific application and includes 5 days of training at CENTROID's facility, followed by 5 days of training at your shop, on your machine.



Fully enclosed cabinet with flood coolant (TSC optional)

Easy access sliding doors with windows

Auto tool length setter

Heavy duty cast iron frame with box ways provides superior accuracy and rigidity

Specially-designed porting tool

24-tool automatic tool changer

10HP 6000RPM spindle

Custom cylinder head fixture plate

Patented ballscrew-driven tilting rotary table

Air blast and coolant wash down hose

USB 2.0 and Ethernet ports standard

MPG electronic handwheel

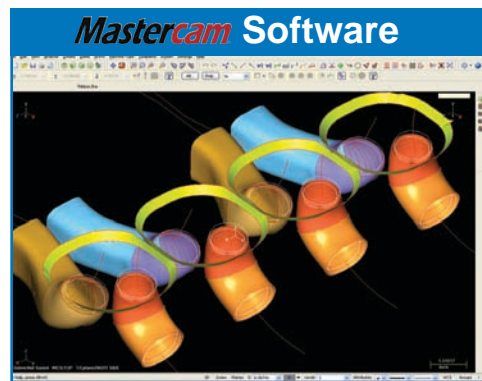

Stay ahead of the competition with the latest version of **Mastercam** CAD/CAM software. CENTROID has partnered with Mastercam to develop new features specifically geared toward cylinder head porting. Easily create and modify intake ports, exhaust ports, and combustion chambers. In addition to porting, this powerful 5-axis software can help you to produce parts you never thought possible.

### Tooling Package



CENTROID offers the most complete turn-key CNC porting system available. Our comprehensive tooling package includes everything you need to go straight into production including the digitizing probe, a custom cylinder head fixture plate, and a carbide lollipop cutter specially designed by CENTROID to provide optimal chip removal and a superior surface finish.

### User-friendly 5-axis CNC



Simple to operate, the CENTROID CNC control is designed with the operator in mind. Graphically assisted part and tool setups along with straightforward menus and an easy to read display ensures every operator will be machining quality cylinder heads in no time. The control software is easily updated giving you access to the latest CNC technology for years to come. Made in the USA.